

1999/05
MOS-FET DC Motor Controller

Holger Zahnleiter
holger@zahnleiter.org *

Date: 07.04.03

Abstract

This circuit has two independent channels and controls two DC motors. It is MOS-FET based and designed for pulse width modulation to regulate the applied power. The direction is switched by relays. Overcurrent is detected and indicated. A microcontroller or microprocessor based system capable for PWM has to be connected to control this MOS-FET motor amplifier.

1 Project characteristics

Project code	1999/05
Project name	MOS-FET DC Motor Controller
Started	28.11.00
Ended	24.03.00
Used tools and libraries	Eagle 3.55 light.
Used for other projects or applications	#1999/01

2 Schema

The figure below illustrates the embedding of the motor controller. The circuit is connected with DC motors and a controlling unit. This unit has to be a circuit capable of generating a PWM signals, e.g. a microcontroller or a CPU.

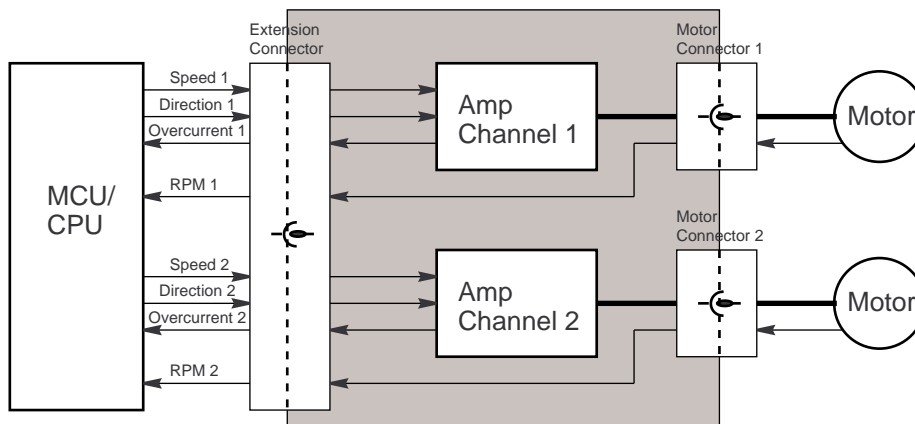

Figure 1: The Schema

*Thanks to Alexander Wiedekind-Klein (awie@roboterwelt.de)

3 Functional Principle

Figure 2 shows the wiring diagram for one channel only. There are just a view things to say about the circuit. One may have noticed that there are two optocouplers used to switch the FET which drives the motor. The couplers are triggered complementary (inverter 7406). This is done to make the FET switch faster. The transition from off (high Ω) to on ($R_{DSon} = 0.02\Omega$) is made faster. As a result the FET doesn't heat up that much.

A Shunt resistor ($150m\Omega$) is used to produce a voltage drop which is directly proportional to the current which goes through the DC motor. A potentiometer ($10k\Omega$) is used to adjust the comperator to indicate that a certain current level is exceeded. The MCU/CPU has to switch the unit off if overcurrent is detected to prevent the MOS-FETs from blowing up.

The motor's direction is changed by a relais. It goes without saying that it is not recommended to switch the relais while the motor is on. Damages may occur on the relais's contacts.

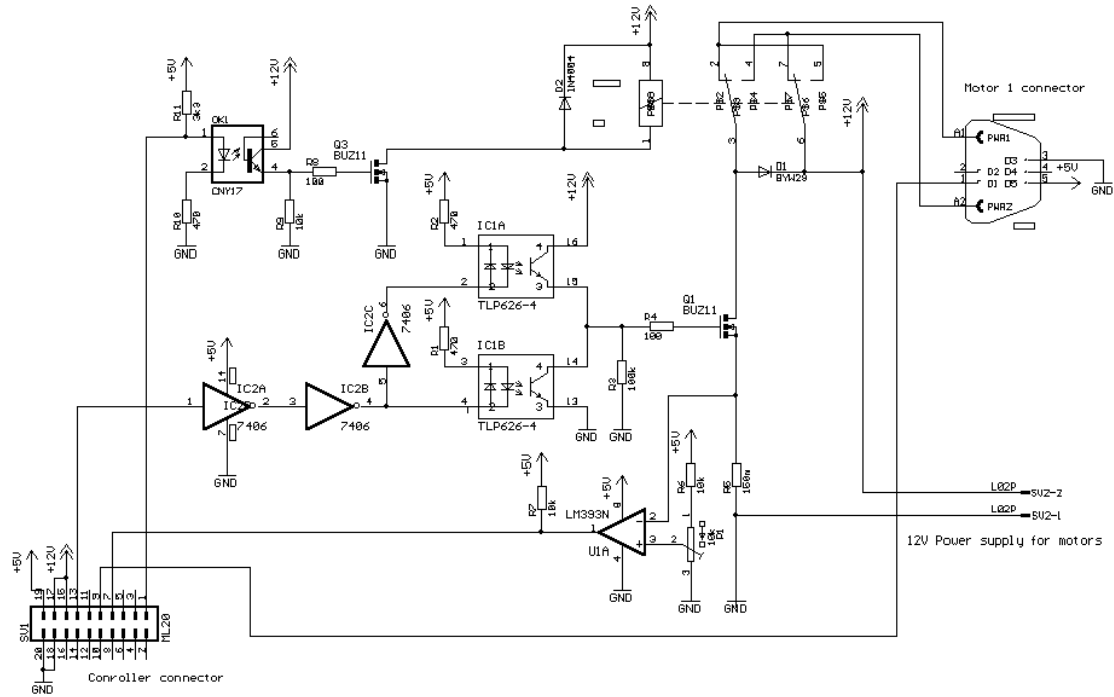

Figure 2: The Wiring Diagram (one Channel only)

4 Adjusting the Overcurrent Detection

One may assume that the current for a motor has to be limited to 2A. With Ohm's law there is a drop of 0.3V at the Shunt.

1. Apply GND and +5V to the circuit via the controller jack.
2. Apply 0.3V to the Shunt resistor.
3. Turn the potentiometer so that the output of the comperator is logic low. Turn back the pot carefully so that the comperator only just turns to logic high.

After this procedure the overcurrent detector indicates currents higher than 2A by going to a logic low. In most cases interrupt inputs are negative edge triggered which perfectly fits with the above circuit!

5 Power Connector

Pin	Description
GND	
+12V (battery)	

Table 2: Power Connector Pinout

6 Controller Jack

This connector has several control and feed back lines. It is to be connected to a controlling device which generates the desired values (direction, rotations per minute (PWM)) and receives/evaluates the actual values (measured data). In this case a 80C517/537 was chosen. The ports mentioned in Table 3 are '517 ports.

Pin	Port	Description
1	P5.2	Direction 1 (desired)
2	P5.3	Direction 2 (desired)
7	P3.2/ $\overline{\text{INT0}}$	Overcurrent 1
8	P3.3/ $\overline{\text{INT1}}$	Overcurrent 2
9	P3.4/T0	Rotations per minute 1 (current)
10	P3.5/T1	Rotations per minute 2 (current)
12	P1.1/CCU1	Power 2 (desired, PWM)
13	P1.2/CCU2	Power 1 (desired, PWM)
15, 17	+12V (battery)	
18, 20	GND	
19	+5V	

Table 3: Controller Jack Pinout

7 Motor Connector

There are two of those connectors mounted on the board, one for each motor. The thick pins supply the motor with the power, the thin ones transmit the measured rotations per minute given by Hall Sensors which are built into the motors.

Pin	Description
1	Rotations per minute sensor 1 (current)
2	Rotations per minute sensor 2 (current)
3	GND
4	n.c.
5	+5V
A1	High power motor contact 1
A2	High power motor contact 2

Table 4: Motor Connector Pinout

8 Testprogram

There is a very basic testprogram to be found on the homepage (`mot_amp_test_bin.hex`) which was designed for an 80C517/535. It might work on a 515/535 as well. It just switches on the motors and changes the direction by switching the relays. The program does not count the pulses nor does it make use of the overcurrent detection.

A Parts list

Name	Part/value	Comments
	Prototype Board	160 x 100 mm
CON1	Connector	Female, 5 x data, 2 x power
CON2	Connector	Female, 5 x data, 2 x power
CON3	VG64 jack	Male, 64 pins (backplane, power supply)
D1	BYW29	Diode
D2	1N4004	Diode
D3	BYW29	Diode
D4	1N4004	Diode
IC1	TLP626-4	Quad optocoupler
IC2	SN74LS06	Six inverter (NOT)
OK1	CNY17	Single optocoupler
OK2	CNY17	Single optocoupler
P1	10k Ω	Resistor (pot)
P2	10k Ω	Resistor (pot)
Q1	BUZ11	MOS-FET
Q2	Relais	2 x toggle
Q3	BUZ11	MOS-FET
Q4	BUZ11	MOS-FET
Q5	Relais	2 x toggle
Q6	BUZ11	MOS-FET
R01	470 Ω	Resistor
R02	470 Ω	Resistor
R03	100k Ω	Resistor
R04	100 Ω	Resistor
R05	150m Ω	Resistor (shunt)
R06	10k Ω	Resistor
R07	10k Ω	Resistor
R08	100 Ω	Resistor
R09	10k Ω	Resistor
R10	470 Ω	Resistor
R11	3k3 Ω	Resistor
R12	470 Ω	Resistor
R13	470 Ω	Resistor
R14	100k Ω	Resistor
R15	100 Ω	Resistor
R16	150m Ω	Resistor (shunt)
R17	10k Ω	Resistor
R18	10k Ω	Resistor
R19	100 Ω	Resistor
R20	10k Ω	Resistor
R21	470 Ω	Resistor
R22	3k3 Ω	Resistor
SV1	Jack	Male, 2 x 10 pins (control, e.g. miniMODUL-537)
SV2	Connector	Male, 2 pins (12V power supply for motors)
U1	LM393N	Comparator

Table 5: Parts list

B List of project files

File Name	Comments
motor_amp.sch	Wiring diagram.
src\test.c	Test program.
src\test.hex	Test program.

Table 6: Project files

C Suppliers

[S1] **FINDER GmbH**
Eisenstrasse 30
65428 Rüsselsheim
Germany
www.finder-gmbh.de/

Relais.

[S2] **Phytec Meßtechnik GmbH**
Robert-Koch-Strasse 39
55129 Mainz
Germany
www.phytec.de/

Microcontroller boards with 8051, C166/167, x86 MCUs/CPUs. Vision systems for automation. Development tools.

D Related web pages

[W1] **Roboterwelt**
www.roboterwelt.de/

All about robots, microcontroller, sensors, ..

Disclaimer

The use of my page's content (programs, wiring diagrams, pictures, documents) is free for non-commercial purposes only.

The information in this document has been carefully reviewed and is believed to be reliable, but I do not assume any liability arising out of the application or use of any documents, programs or circuit described herein.

Furthermore I want to declare that I'm not responsible in any way for the content of other web pages, books and other sources I'm referring to.